



ATAR course examination, 2021

PHYSICAL EDUCATION STUDIES

Practical (performance) examination Netball

Time allowed

Preparation: 30 minutes
Examination: 60 minutes (30 minute performance)

Materials required

To be provided at the venue

Non-personal equipment required for Netball

To be provided by the candidate

Non-marking athletic shoes

Structure of the examination

The Physical Education Studies ATAR course examination consists of a written component and a practical (performance) component.

Criteria for marking the practical (performance) examination

Criteria	Marks available	Percentage of total exam
Skills performance	30	50
Conditioned performance	20	50
Total		100

Instructions to candidates

1. You are required to wear clothing and personal playing and safety equipment that is approved for competition by the sport's governing body.
2. Clothing must not identify you, your school, club or achievements, and it is requested that you wear black, navy or a white shirt for the examination.
3. You are required to report to a supervisor to register for the practical examination 40 minutes before your scheduled examination time.
4. Once your attendance has been recorded you will be given a coloured, numbered bib to wear for the examination and you will be directed to a supervised warm-up area.
5. Just prior to the scheduled examination time you will be escorted from the warm-up area to the examination area.
6. You must follow the requirements for this examination published in the *Physical Education Studies ATAR course Practical (performance) examination requirements 2021* document.

SECTION ONE – Skills Performance

1. Skills set

(30 marks)

Skill 1	Skill 2	Skill 3	Skill 4	Skill 5
Lob pass	3 feet (0.9m) recovery	Outside foot land and pivot	Split and re-offer	Shadowing

Drill #1: Lob pass, 3 feet (0.9m) recovery

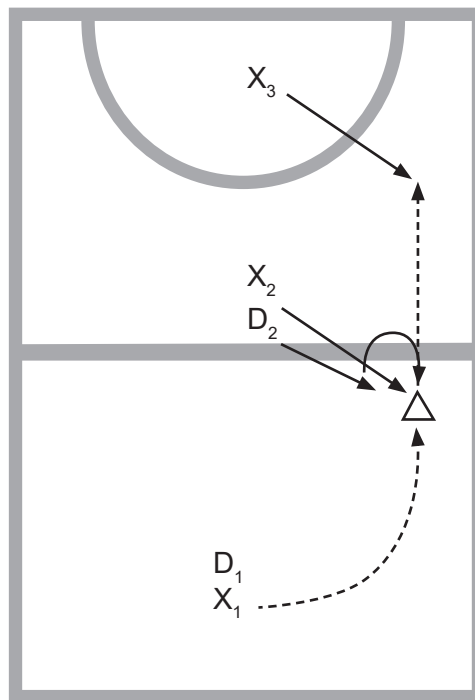

Key:

- X = player
- D = defender
- △ = marker
- = player movement
- > = ball movement

Drill description:

1. Player X₁ lobs over defender D₁ to player X₂.
2. Defender D₂ then does a 3 foot recovery on player X₂ who is passing to player X₃ who leads to receive a pass from player X₂.
3. Player X₂ passes to leading player X₃.
3. Repeat on opposite side of court.

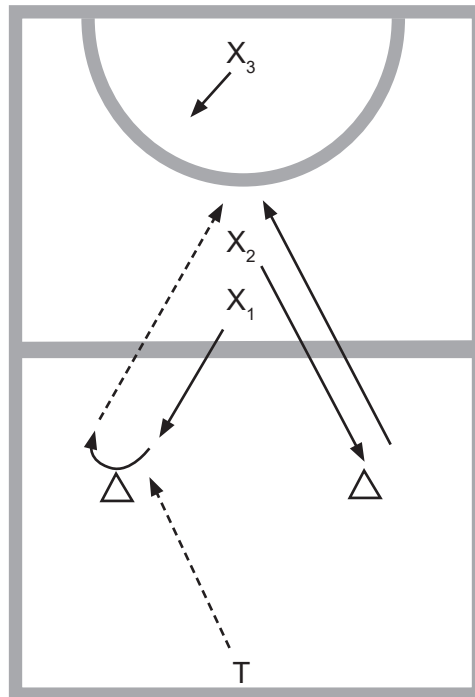
Drill #2: Outside foot land and pivot, split and re-offer

Key:

X = player
 T = thrower
 △ = marker
 —————> = player movement
 - - - - -> = ball movement

Drill description:

1. Set up in the centre third of the court with thrower (floor supervisor) in the centre circle.
2. Players X₁ and X₂ start behind transverse line.
3. Thrower throws ball to self to create timing for the two attackers to lead.
4. On the catch by the thrower, both players X₁ and X₂ offer a split lead for the ball. Player X₁ has the choice of leading to the left or right but must use a combination of both.
5. Thrower passes to player X₁.
6. Player X₁ completes the split lead then executes an outside foot land and pivot.
7. Player X₂ completes the split lead then re-offers back down court on an angle.
8. Player X₁ passes a shoulder pass to player X₂ on the re-offer lead.
9. Player X₂ passes to leading player X₃ (X₃ may lead in any direction).

See next page

Drill #3: Shadowing

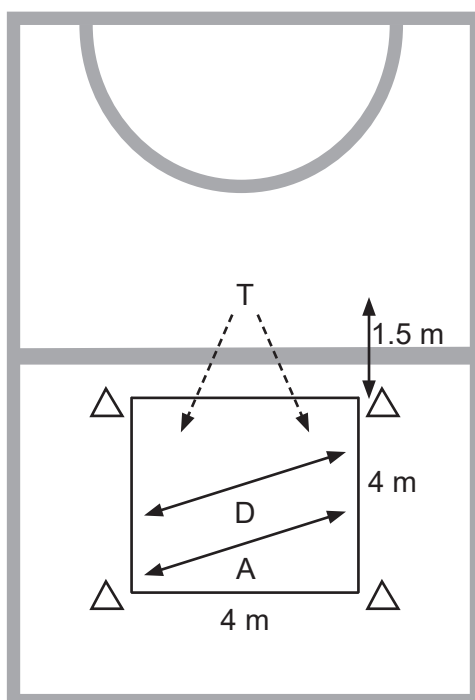

- Key:**
- A = attacker
 - D = defender
 - T = thrower (floor supervision)
 - △ = marker
 - = player movement
 - = ball movement

Drill description:

1. Skills are to be performed inside the 4 m x 4 m grid set up with markers.
2. The thrower (T) is positioned 1.5 m outside the grid. T throws the ball to self to create timing for the attacker and defender to begin.
3. Starting position for A and D is in the centre of the grid. D takes up a defensive stance with their back to A.
4. On the catch by the thrower, A is to use a dodge in a lateral direction (left and right) using the grid indicated by the markers to evade D and receive a pass. A must receive the pass inside the marked grid.
5. D is to shadow defend A's movements.
6. D must maintain their head position, cover A's movements and intercept or deny the pass.
7. Repeat with head and body positioned the other way.

See next page

SECTION TWO – Conditioned Performance

(20 marks)

SCENARIO PLANNING	
DEFINE PLAYING AREA OR BOUNDARIES	Half court
SPECIFY NUMBER OF PLAYERS	4 vs 4 Offence: GS, GA, WA, C Defence: GK, GD, WD, C
SPECIFY TACTICAL PROBLEM(S) TO BE SOLVED	Creating a scoring shot from a centre pass.
SPECIFY ROLES OR GOALS OF PLAYER(S)	No special notes
SPECIFY OPTIONS, RULES AND/OR RESTRICTIONS	Normal position rules apply. Change offence and defence after 5 minutes.

Conditioned Performance - Half Court Game Scenario

1. You will be in Netball Positional Bibs.
2. The rotation of these bibs will be controlled by the Examiners.
3. You will start in traditional playing areas on court.
4. Attackers aim – play from the centre pass to the goal circle and shoot for a goal.
5. Defenders aim – to stop the attackers from getting the ball to a shot for goal.
6. Defenders – if a goal is scored you will take a goal line throw in and play ball past the centre circle.
7. If a defender intercepts the pass, play the ball back past the centre circle and the game recommences with the next centre pass.
8. If the ball is tipped out of court or thrown out of court – the opposition team will be awarded the throw in.
9. All other official Netball rules apply.

End of examination

This document – apart from any third party copyright material contained in it – may be freely copied, or communicated on an intranet, for non-commercial purposes in educational institutions, provided that it is not changed and that the School Curriculum and Standards Authority is acknowledged as the copyright owner, and that the Authority's moral rights are not infringed.

Copying or communication for any other purpose can be done only within the terms of the *Copyright Act 1968* or with prior written permission of the School Curriculum and Standards Authority. Copying or communication of any third party copyright material can be done only within the terms of the *Copyright Act 1968* or with permission of the copyright owners.

Any content in this document that has been derived from the Australian Curriculum may be used under the terms of the Creative Commons [Attribution 4.0 International \(CC BY\)](https://creativecommons.org/licenses/by/4.0/) licence.

An *Acknowledgements variation* document is available on the Authority website.

*Published by the School Curriculum and Standards Authority of Western Australia
303 Sevenoaks Street
CANNINGTON WA 6107*